

CAST STEEL VALVES

CLASS 150/300/600
GATE, GLOBE and SWING CHECK



A general engineering group dealing with valves for petroleum refining, petrochemical, thermal power plants, and other process industries

Ishida Valve Mfg. Co., Ltd.
Ishida Valve Engineering Co., Ltd.

CAST STEEL VALVES

INDEX

CLASS	FIG.NO.	TYPE	END CONNECTION	PAGE
150	C2240 C2230	GATE VALVE	RF FLANGED BUTT WELD	3
300	C2440 C2470 C2430	GATE VALVE	RF FLANGED RJ FLANGED BUTT WELD	4
600	C2640 C2670 C2630	GATE VALVE	RF FLANGED RJ FLANGED BUTT WELD	5
150	C1240 C1230	GLOBE VALVE	RF FLANGED BUTT WELD	6
300	C1440 C1470 C1430	GLOBE VALVE	RF FLANGED RJ FLANGED BUTT WELD	7
600	C1640 C1670 C1630	GLOBE VALVE	RF FLANGED RJ FLANGED BUTT WELD	8
150	C4240 C4230	SWING CHECK VALVE	RF FLANGED BUTT WELD	9
300	C4440 C4470 C4430	SWING CHECK VALVE	RF FLANGED RJ FLANGED BUTT WELD	10
600	C4640 C4670 C4630	SWING CHECK VALVE	RF FLANGED RJ FLANGED BUTT WELD	11

————— FIGURE NUMBERS —————

BODY/BONNET MATERIAL ←

C — ASTM A216 WCB
 F — ASTM A217 WC1
 H — ASTM A217 WC6
 I — ASTM A217 C5
 S — ASTM A352 LCB
 W — ASTM A352 LC3

→ **TRIM**

H — HALF STELLITE
 B — FULL STELLITE
 C — 304 SS
 C1 — 316 SS
 M — MONEL

FIG. C-2240-H

CAST STEEL GATE VALVES

ASME CLASS 150

SIZE 2 "to 48 "
Flanged and Butt weld Ends
Bolted Bonnet, O.S. & Y.
R.F. End Type. Fig. No. C2240
B.W. End Type. Fig. No. C2230

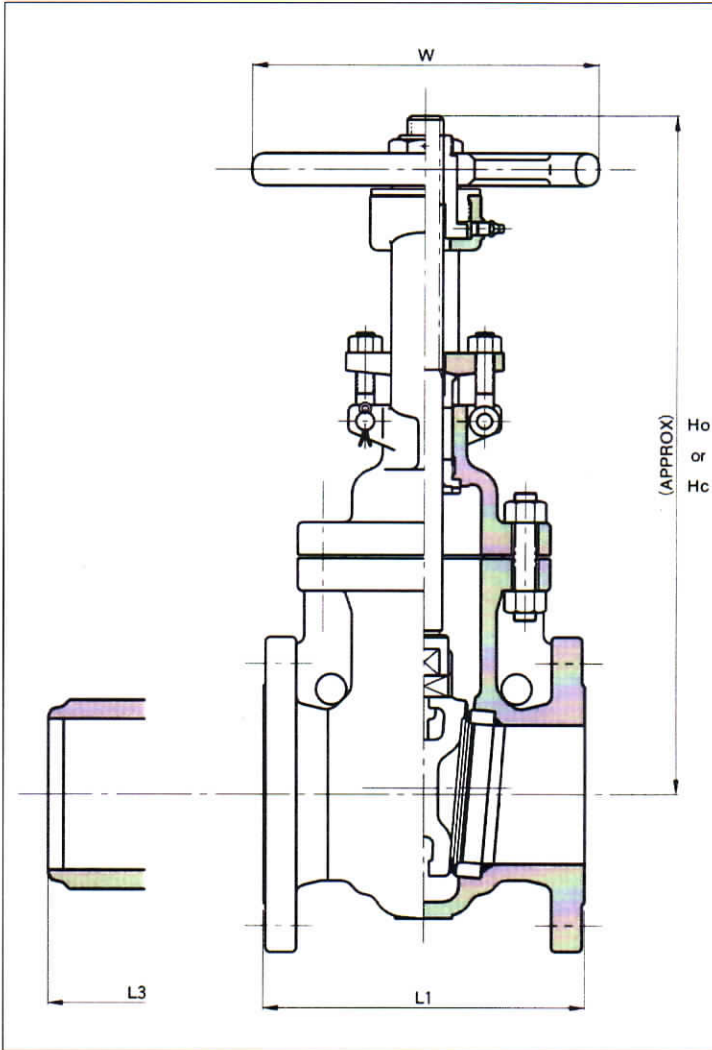

PRESSURE TEST: As per API 598

MATERIAL

NAME OF PART	ASTM	JIS
BODY	A216 WCB	SCPH2
BODY SEAT RING	* A105	* SFVC2A
DISC	* A216 WCB	* SCPH2
STEM	A182 F6a	SUS403
BONNET GASKET	REIN FORCED GRAPHITE	
BONNET	A216 WCB	SCPH2
BONNET BOLT	A193 B7	SNB7
BONNET BOLT NUT	A194 2H	S45C
BONNET BUSH	A276 420	SUS420J2
GLAND PACKING	FLEXIBLE GRAPHITE	
GLAND	A276 420	SUS420J2
GLAND FLANGE	A105	SFVC2A
GLAND EYE BOLT	A193 B7	SNB7
GL. EYE BOLT NUT	A194 2H	S45C
YOKE	A216 WCB	SCPH2
YOKE SLEEVE	A439 D2	FCDA NiCr
SLEEVE NUT	A576 1025	S25C
HAND WHEEL	A536	FCD450
LOCK NUT	A36	SS400
NAME PLATE	B209M	ALP

* BODY SEAT RING: STELLITE FACE
 * DISC: 13Cr FACE

- Note: (1) Disc of valves 2½ inch and under are solid wedge. 3 inch and over are flexible wedge.
 (2) Valves 12 inch and over have thrust bearing.
 (3) Operation of valves 18 inch and over have bevel gear unit.

WEIGHT AND DIMENSIONS

Valve Size		2"	2½"	3"	4"	6"	8"	10"	12"	14"	16"	18"	20"	24"	26"	28"	30"	32"	34"	36"	38"	40"	42"	48"
End to End (mm)	R.F. L1	178	190	203	229	267	292	330	356	384	406	432	457	508	559	610	610	660	711	711	736	762	787	864
	B.W. L3	216	241	283	305	403	418	457	502	572	610	660	711	813	864	914	914	965	1016	1016	1041	1041	1118	1168
Center to Top (mm)	Open Ho	383	418	472	576	801	1012	1232	1427	1550	1734	1928	2167	2533	2818	3078	3202	3465	3480	4052	4120	4340	4583	5200
	Close Hc	324	346	387	464	635	701	960	1103	1192	1330	1928	2167	2533	2818	3078	3202	3465	3480	4052	4120	4340	4583	5200
Diam. of Handwheel (mm)	W	200	200	250	250	300	355	400	520	550	600	460	460	610										
Weight Approx. (kg)	R.F.	18	24	32	50	84	130	198	280	370	496	655	836	1186										
	B.W.	16	20	39	44	79	110	187	270	335	480	625	760	1000										

CAST STEEL GATE VALVES

ASME CLASS 300

SIZE 2 "to 36 "
Flanged and Butt weld Ends
Bolted Bonnet, O.S. & Y.
R.F. End Type. Fig. No. C2240
R.J. End Type. Fig. No. C2270
B.W. End Type. Fig. No. C2230

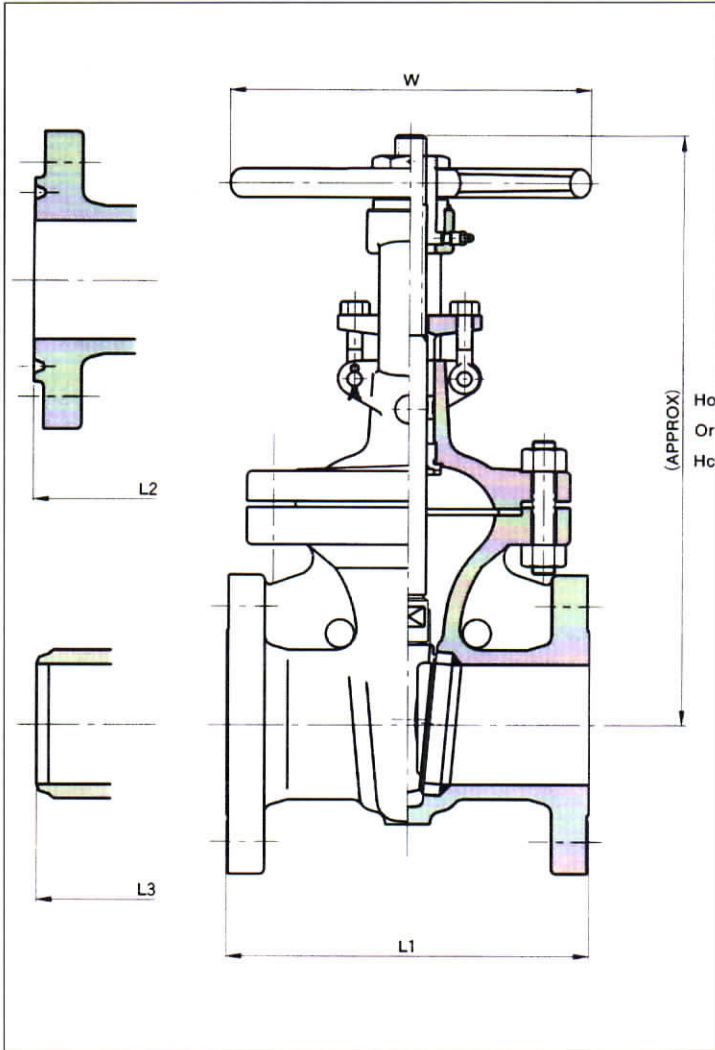

PRESSURE TEST: As per API 598

MATERIAL

NAME OF PART	ASTM	JIS
BODY	A216 WCB	SCPH2
BODY SEAT RING	* A105	* SFVC2A
DISC	* A216 WCB	* SCPH2
STEM	A182 F6a	SUS403
BONNET GASKET	SPIRAL WOUND GRAPHOIL	
BONNET	A216 WCB	SCPH2
BONNET BOLT	A193 B7	SNB7
BONNET BOLT NUT	A194 2H	S45C
BONNET BUSH	A276 420	SUS420J2
LANTERN RING	A276 420	SUS420J2
GLAND PACKING	FLEXIBLE GRAPHITE	
GLAND	A276 420	SUS420J2
GLAND FLANGE	A105	SFVC2A
GLAND EYE BOLT	A193 B7	SNB7
GL. EYE BOLT NUT	A194 2H	S45C
YOKE	A216 WCB	SCPH2
YOKE SLEEVE	A439 D2	FCDA NiCr
SLEEVE NUT	A576 1025	S25C
HAND WHEEL	A536	FCD450
LOCK NUT	A36	SS400
NAME PLATE	B209M	ALP

* BODY SEAT RING: STELLITE FACE
 * DISC: 13Cr FACE

- Note: (1) Disc of valves 2½ inch and under are solid wedge. 3 inch and over are flexible wedge.
- (2) Valves 10 inch and over have thrust bearing.
- (3) Operation of valves 14 inch and over have bevel gear unit.

WEIGHT AND DIMENSIONS

Valve Size		2"	2½"	3"	4"	6"	8"	10"	12"	14"	16"	18"	20"	24"	26"	28"	30"	32"	34"	36"
End to End (mm)	R.F. L1	216	241	283	305	403	419	457	502	762	838	914	991	1143	1245	1346	1397	1524	1626	1727
	R.J. L2	232	257	298	321	419	435	473	518	778	854	930	1010	1165	1270	1371	1422	1553	1655	1756
	B.W. L3	216	241	283	305	403	419	457	502	762	838	914	991	1143	1245	1346	1397	1524	1626	1727
Center to Top (mm)	Open Ho	416	456	496	614	846	1080	1285	1486	1643	1820	2032	2220	2635	2844	3021	3481	3630	3780	3920
	Close Hc	357	384	421	502	680	1013	1162	520	1643	1820	2032	2220	2635	2844	3021	3481	3630	3780	3920
Diam. of Handwheel (mm)	W	200	200	250	300	355	450	500	600	460	460	460	610	610	610	610	610	610	762	762
Weight Approx. (kg)	R.F.	28	43	53	75	152	232	340	480	725	1000	1270	1500	2400						
	R.J.	28	43	53	75	152	232	340	480	725	1000	1270	1500	2400						
	B.W.	23	34	48	60	125	196	265	396	620	810	1076	1450	2100						

CAST STEEL GATE VALVES

ASME CLASS 600

SIZE 2 "to 26 "
Flanged and Butt weld Ends
Bolted Bonnet, O.S. & Y.
R.F. End Type. Fig. No. C2640
R.J. End Type. Fig. No. C2670
B.W. End Type. Fig. No. C2630

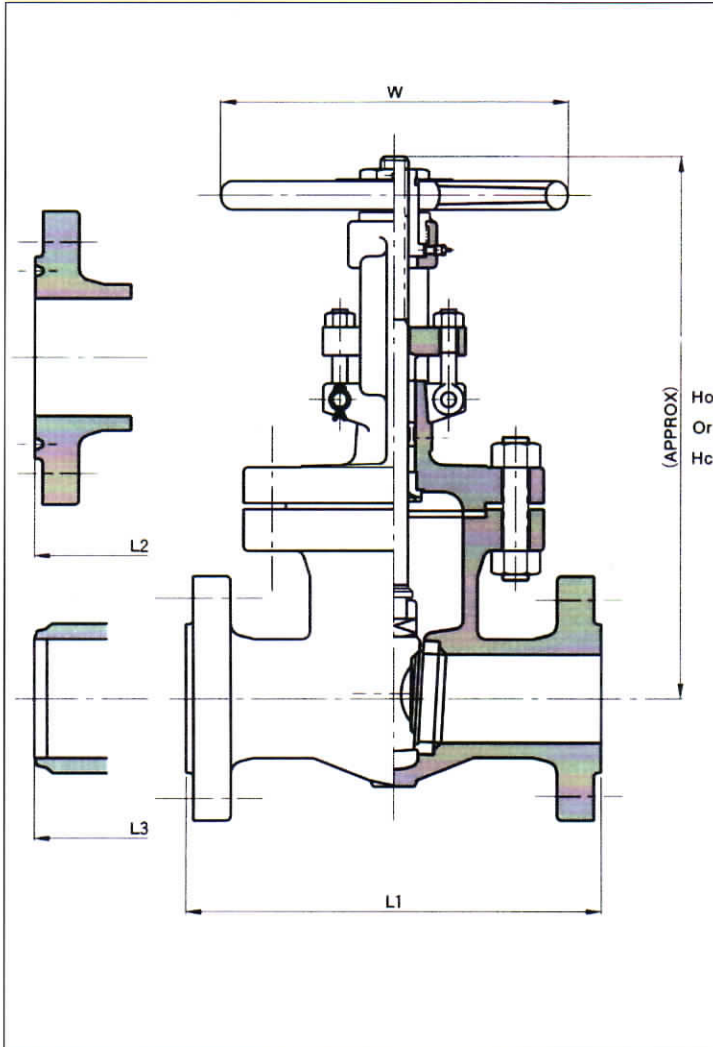

PRESSURE TEST: As per API 598

MATERIAL		
NAME OF PART	ASTM	JIS
BODY	A216 WCB	SCPH2
BODY SEAT RING	* A105	* SFVC2A
DISC	* A216 WCB	* SCPH2
STEM	A182 F6a	SUS403
BONNET GASKET	SPIRAL WOUND GRAPHOIL	
BONNET	A216 WCB	SCPH2
BONNET BOLT	A193 B7	SNB7
BONNET BOLT NUT	A194 2H	S45C
BONNET BUSH	A276 420	SUS420J2
LANTERN RING	A276 420	SUS420J2
GLAND PACKING	FLEXIBLE GRAPHITE	
GLAND	A276 420	SUS420J2
GLAND FLANGE	A105	SFVC2A
GLAND EYE BOLT	A193 B7	SNB7
GL. EYE BOLT NUT	A194 2H	S45C
YOKE	A216 WCB	SCPH2
YOKE SLEEVE	A439 D2	FCDA NiCr
SLEEVE NUT	A576 1025	S25C
HAND WHEEL	A536	FCD450
LOCK NUT	A36	SS400
NAME PLATE	B209M	ALP

* BODY SEAT RING: STELLITE FACE
 * DISC: 13Cr FACE

- Note: (1) Disc of valves 2½ inch and under are solid wedge. 3 inch and over are flexible wedge.
- (2) Valves 6 inch and over have thrust bearing.
- (3) Operation of valves 12 inch and over have bevel gear unit.

WEIGHT AND DIMENSIONS

Valve Size		2"	2½"	3"	4"	6"	8"	10"	12"	14"	16"	18"	20"	24"	26"	
End to End (mm)	R.F.	L1	292	330	356	432	559	660	787	838	889	991	1092	1194	1397	1448
	R.J.	L2	295	333	359	435	562	664	791	841	892	994	1095	1200	1407	1458
	B.W.	L3	292	330	356	432	559	660	787	838	889	991	1092	1194	1397	1448
Center to Top (mm)	Open	Ho	473	505	555	692	1006	1188	1402	1633	1772	2038	2218	2392	2822	3050
	Close	Hc	414	433	471	580	843	973	1136	1633	1772	2038	2218	2392	2822	3050
Diam. of Handwheel(mm)	W		250	250	300	355	500	600	685	457	610	610	610	610	760	760
Weight Approx.(kg)	R.F.		46	63	75	125	285	475	757	1015	1400	1710	2210	3220	4250	
	R.J.		48.5	64	78	140	285	475	757	1015	1400	1710	2210	3220	4250	
	B.W.		45	56	67	110	208	385	610	840	1150	1530	2000	2600	4100	

CAST STEEL GLOBE VALVES

ASME CLASS 150

SIZE 2 "to 20 "
Flanged and Butt weld Ends
Bolted Bonnet, O.S. & Y.
R.F. End Type. Fig. No. C1240
B.W. End Type. Fig. No. C1230

PRESSURE TEST: As per API 598

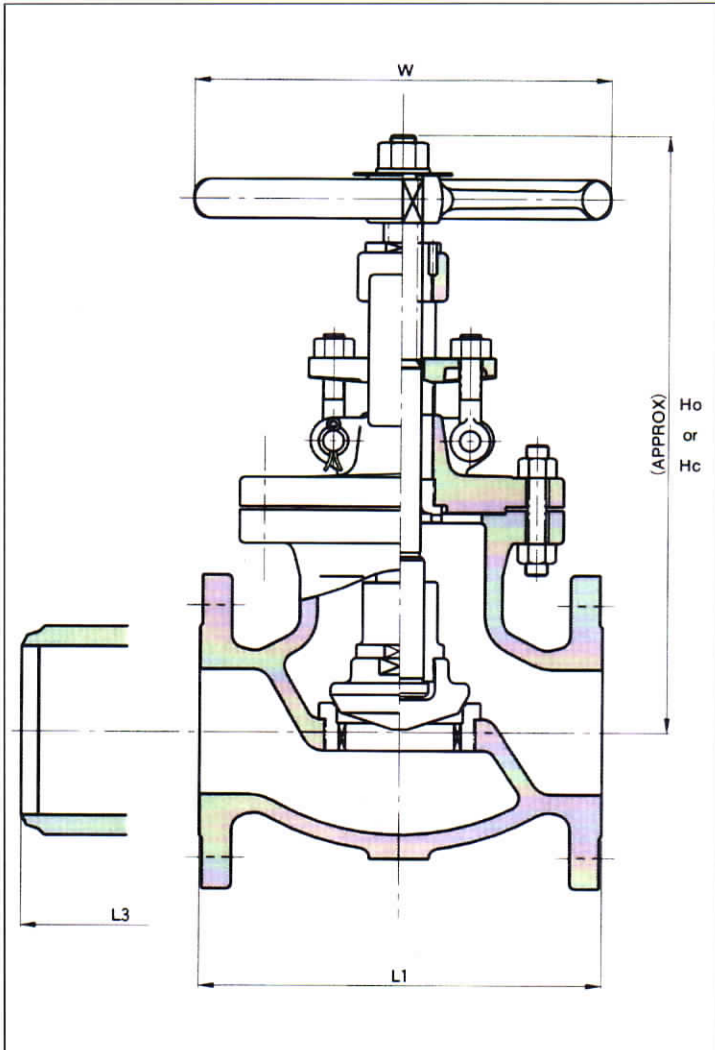

MATERIAL

NAME OF PART	ASTM	JIS
BODY	A216 WCB	SCPH2
BODY SEAT RING	* A105	* SFVC2A
DISC STEM RING	A276 420	SUS420J2
DISC	A276 420	SUS420J2
STEM	A182 F6a	SUS403
BONNET GASKET	SPIRAL WOUND GRAPHOIL	
BONNET	A216 WCB	SCPH2
BONNET BOLT	A193 B7	SNB7
BONNET BOLT NUT	A194 2H	S45C
BONNET BUSH	A276 420	SUS420J2
GLAND PACKING	FLEXIBLE GRAPHITE	
GLAND	A276 420	SUS420J2
GLAND FLANGE	A105	SFVC2A
GLAND EYE BOLT	A193 B7	SNB7
GL. EYE BOLT NUT	A194 2H	S45C
YOKE SLEEVE	A439 D2	FCDA NiCr
HAND WHEEL	A536	FCD450
LOCK NUT	A36	SS400
NAME PLATE	B209M	ALP

* BODY SEAT RING: STELLITE FACE
 * DISC: 12 INCH AND OVER ARE WCB WITH 13Cr FACE

Note: (1) Stem of valves 10 inch and over are non-rotating type

WEIGHT AND DIMENSIONS

Valve Size			2"	2½"	3"	4"	6"	8"	10"	12"	14"	16"	18"	20"
End to End (mm)	R.F.	L1	203	216	241	292	406	495	622	698	787	914	978	978
	B.W.	L3	203	216	241	292	406	495	622	698	787	914	978	978
Center to Top (mm)	Open	Ho	338	347	388	424	485	598	698	837	1031	1121	1200	1250
	Close	Hc	320	325	362	389	438	538	623	752	926	1101	1200	1250
Diam. of Handwheel (mm)		W	200	200	250	280	355	450	450	560	685	685	610	610
Weight Approx. (kg)	R.F.		20.5	33.0	34.5	52	94	150	305	476	620	766	1000	1300
	B.W.		19	30	33	49	90	173	275	430	560	690	690	1170

CAST STEEL GLOBE VALVES

ASME CLASS 300

SIZE 2 "to 16 "
Flanged and Butt weld Ends
Bolted Bonnet, O.S. & Y.
R.F. End Type. Fig. No. C1440
R.J. End Type. Fig. No. C1470
B.W. End Type. Fig. No. C1430

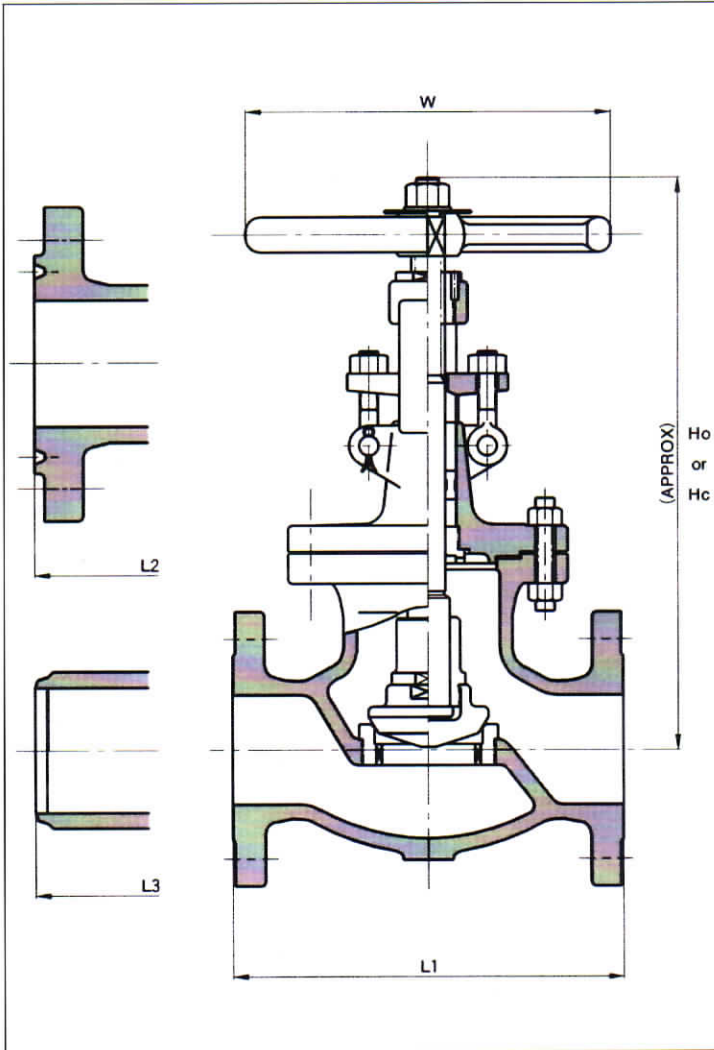

PRESSURE TEST: As per API 598

MATERIAL

NAME OF PART	ASTM	JIS
BODY	A216 WCB	SCPH2
BODY SEAT RING	* A105	* SFVC2A
DISC STEM RING	A276 420	SUS420J2
DISC	A276 420	SUS420J2
STEM	A182 F6a	SUS403
BONNET GASKET	SPIRAL WOUND GRAPHOIL	
BONNET	A216 WCB	SCPH2
BONNET BOLT	A193 B7	SNB7
BONNET BOLT NUT	A194 2H	S45C
BONNET BUSH	A276 420	SUS420J2
LANTERN RING	A276 420	SUS420J2
GLAND PACKING	FLEXIBLE GRAPHITE	
GLAND	A276 420	SUS420J2
GLAND FLANGE	A105	SFVC2A
GLAND EYE BOLT	A193 B7	SNB7
GL. EYE BOLT NUT	A194 2H	S45C
YOKE BUSH	A439 D2	FCDA NiCr
HAND WHEEL	A536	FCD450
LOCK NUT	A36	SS400
NAME PLATE	B209M	ALP

* BODY SEAT RING: STELLITE FACE
 * DISC: 12 INCH AND OVER ARE WCB WITH 13Cr FACE

Note: (1) Stem of valves 8 inch and over are non-rotating type

WEIGHT AND DIMENSIONS

Valve Size			2"	2½"	3"	4"	6"	8"	10"	12"	14"	16"
End to End (mm)	R.F.	L1	267	292	318	356	444	559	622	711	800	940
	R.J.	L2	283	308	333	371	460	575	638	727	816	956
	B.W.	L3	267	292	318	356	444	559	622	711	800	940
Center to Top (mm)	Open	Ho	380	416	444	525	668	830	992	1136	1298	1400
	Close	Hc	362	394	418	490	621	770	920	1046	1298	1400
Diam. of Handwheel(mm)	W		200	250	280	355	450	560	610	685	610	610
Weight Approx.(kg)	R.F.		25.5	47	51	84	148	230	450	650	940	1280
	R.J.		28	53	57	91	187	332	500	714	987	1344
	B.W.		24	45	49	78	160	285	428	610	846	1150

CAST STEEL GLOBE VALVES

ASME CLASS 600

SIZE 2 "to 16 "
Flanged and Butt weld Ends
Bolted Bonnet, O.S. & Y.
R.F. End Type. Fig. No. C1640
R.J. End Type. Fig. No. C1670
B.W. End Type. Fig. No. C1630

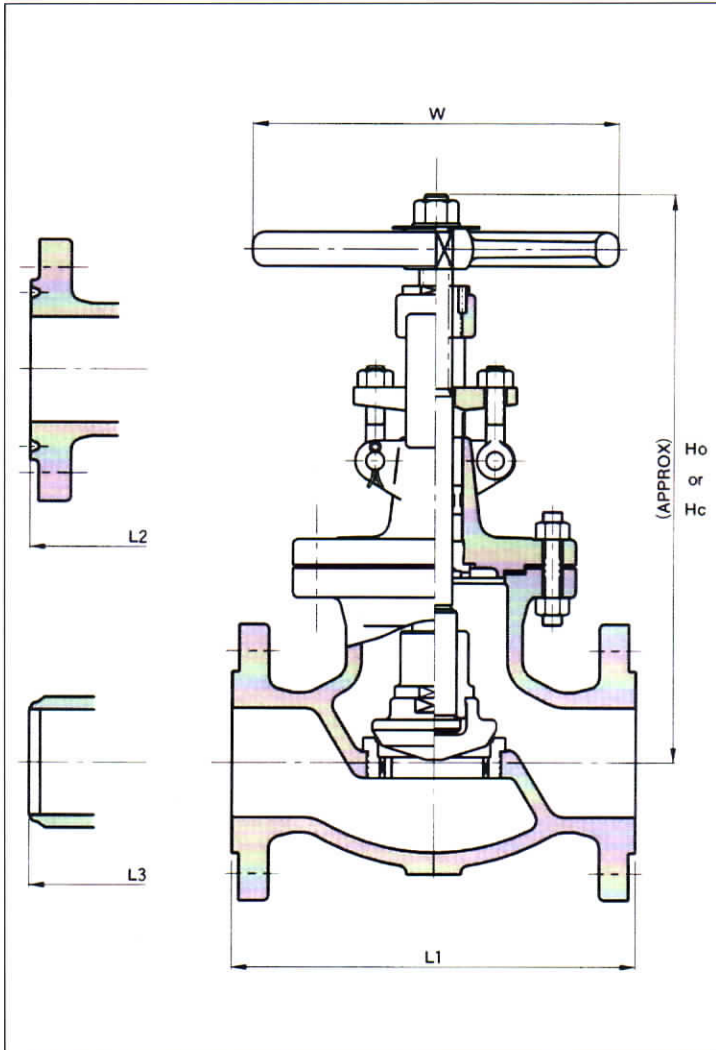

PRESSURE TEST: As per API 598

MATERIAL

NAME OF PART	ASTM	JIS
BODY	A216 WCB	SCPH2
BODY SEAT RING	* A105	* SFVC2A
DISC STEM RING	A276 420	SUS420J2
DISC	A276 420	SUS420J2
STEM	A182 F6a	SUS403
BONNET GASKET	SPIRAL WOUND GRAPHOIL	
BONNET	A216 WCB	SCPH2
BONNET BOLT	A193 B7	SNB7
BONNET BOLT NUT	A194 2H	S45C
BONNET BUSH	A276 420	SUS420J2
LANTERN RING	A276 420	SUS420J2
GLAND PACKING	FLEXIBLE GRAPHITE	
GLAND	A276 420	SUS420J2
GLAND FLANGE	A105	SFVC2A
GLAND EYE BOLT	A193 B7	SNB7
GL. EYE BOLT NUT	A194 2H	S45C
YOKE BUSH	A439 D2	FCDA NiCr
HAND WHEEL	A536	FCD450
LOCK NUT	A36	SS400
NAME PLATE	B209M	ALP

* BODY SEAT RING: STELLITE FACE
 * DISC: 8 INCH AND OVER ARE WCB WITH 13Cr FACE

Note: (1) Stem of valves 8 inch and over are non-rotating type

WEIGHT AND DIMENSIONS

Valve Size		2"	2½"	3"	4"	6"	8"	10"	12"	14"	16"	
End to End (mm)	R.F.	L1	292	330	356	432	559	660	787	838	889	991
	R.J.	L2	295	333	359	435	562	664	791	841	892	994
	B.W.	L3	292	330	356	432	559	660	787	838	889	991
Center to Top (mm)	Open	Ho	493	469	630	704	852	1072	1100	1300	1400	1500
	Close	Hc	435	435	589	654	792	997	1000	1300	1400	1500
Diam. of Handwheel(mm)	W	280	280	355	450	560	685	760	610	610	610	
Weight Approx.(kg)	R.F.		45	60	83	150	327	552	910	1150	1600	2160
	R.J.		45.5	65	83	155	327	520	910	1150	1600	2160
	B.W.		36	47	58	114	258	460	720	850	1400	1900

CAST STEEL SWING CHECK VALVES ASME CLASS 150

SIZE 2 "to 30 "
Flanged and Butt weld Ends
Bolted Cover Type.
R.F. End Type. Fig. No. C4240
B.W. End Type. Fig. No. C4230

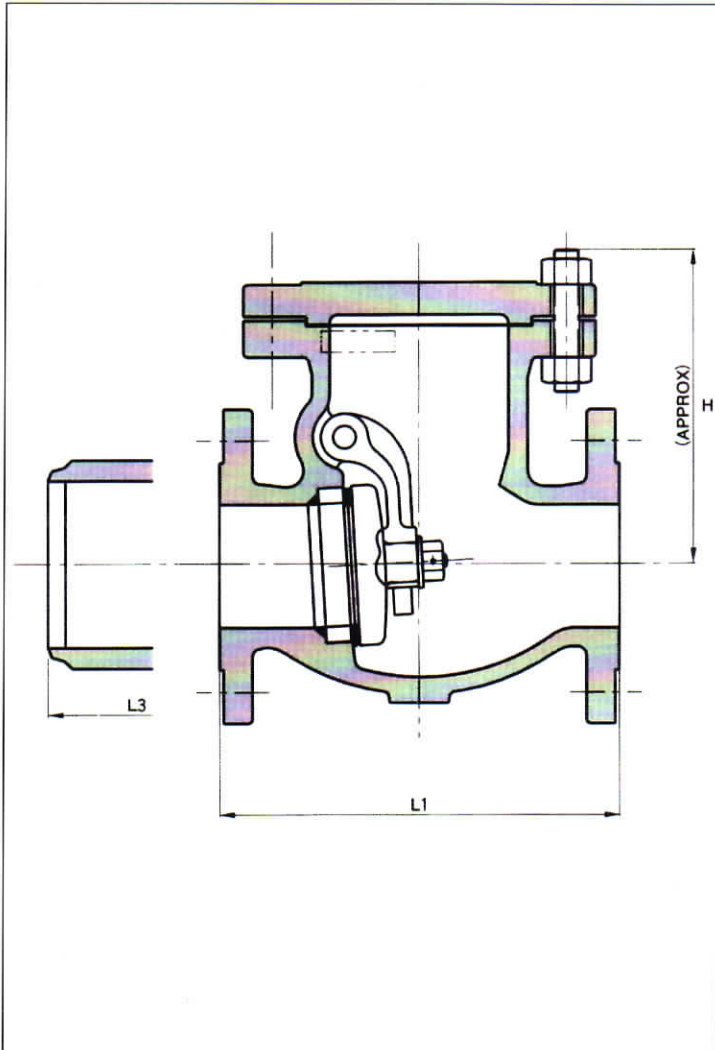

PRESSURE TEST: As per API 598

MATERIAL

NAME OF PART	ASTM	JIS
BODY	A216 WCB	SCPH2
BODY SEAT RING	* A105	* SFVC2A
DISC	4" & UNDER	* SFVC2A
	6" & OVER	* SCPH2
HINGE	A216 WCB	SCPH2
HINGE PIN	A276 410/420	SUS403
COVER	A216 WCB	SCPH2
COVER BOLT	A193 B7	SNB7
COVER BOLT NUT	A194 2H	S45C
COVER GASKET	SPIRAL WOUND GRAPHOIL	
KNOCK PIN	A276 304	SUS304
DISC NUT	A276 410/420	SUS403
DISC WASHER	A276 410/420	SUS403
PLUG	A276 410/420	SUS403
NAME PLATE	B209M	ALP
PLUG GASKET	A576	MILD STEEL

* BODY SEAT RING: STELLITE FACE
 * DISC: 13Cr FACE

Note: (1) Valves 6 inch and over are equipped with eye-bolts.(Mild Steel)

WEIGHT AND DIMENSIONS

Valve Size			2"	2½"	3"	4"	6"	8"	10"	12"	14"	16"	18"	20"	24"	26"	28"	30"
End to End (mm)	R.F.	L1	203	216	241	292	356	495	622	698	787	864	978	978	1295	1295	1448	1524
	B.W.	L3	203	216	241	292	356	495	622	698	787	864	978	978	1295	1295	1448	1524
Center to Top(mm)		H	163	180	190	220	300	335	389	435	511	540	599	614	817	870	950	1000
Weight Approx.(kg)	R.F.		20	26	35	55	87	150	270	380	475	575	770	820	1383			
	B.W.		16	23	30	47	74	119	195	270	400	467	655	800	1280			

CAST STEEL SWING CHECK VALVES ASME CLASS 300

SIZE 2 "to 24 "
Flanged and Butt weld Ends
Bolted Cover Type.
R.F. End Type. Fig. No. C4440
R.J. End Type. Fig. No. C4470
B.W. End Type. Fig. No. C4430

PRESSURE TEST: As per API 598

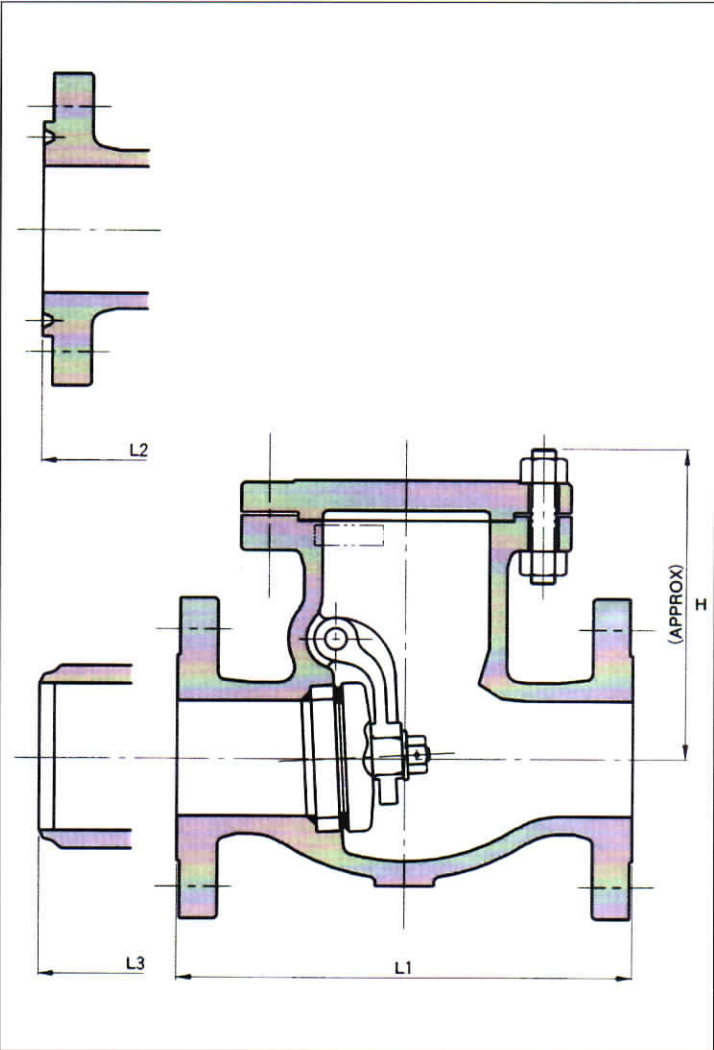

MATERIAL

NAME OF PART	ASTM	JIS
BODY	A216 WCB	SCPH2
BODY SEAT RING	* A105	* SFVC2A
DISC	4" & UNDER	* A105
	6" & OVER	* A216 WCB
HINGE	A216 WCB	SCPH2
HINGE PIN	A276 410/420	SUS403
COVER	A216 WCB	SCPH2
COVER BOLT	A193 B7	SNB7
COVER BOLT NUT	A194 2H	S45C
COVER GASKET	SPIRAL WOUND GRAPHOIL	
KNOCK PIN	A276 304	SUS304
DISC NUT	A276 410/420	SUS403
DISC WASHER	A276 410/420	SUS403
PLUG	A276 410/420	SUS403
NAME PLATE	B209M	ALP
PLUG GASKET	A576	MILD STEEL

* BODY SEAT RING: STELLITE FACE
 * DISC: 13Cr FACE

Note: (1) Valves 6 inch and over are equipped with eye-bolts.(Mild Steel)

WEIGHT AND DIMENSIONS

Valve Size		2"	2½"	3"	4"	6"	8"	10"	12"	14"	16"	18"	20"	24"	
End to End (mm)	R.F.	L1	267	292	318	356	444	533	622	711	838	864	978	1016	1346
	R.J.	L2	283	308	333	371	460	549	638	727	854	879	994	1035	1368
	B.W.	L3	267	292	318	356	444	533	622	711	838	864	978	1016	1346
Center to Top(mm)	H	181	202	219	282	332	391	427	481	513	655	679	703	843	
Weight Approx.(kg)	R.F.		30	49	54	76.5	143	220	343	468	665	840	1095	1283	2200
	R.J.		30	49	54	76.5	143	220	343	468	665	840	1095	1283	2200
	B.W.		26	39	50	60	120	195	290	350	565	715	930	1100	1870

CAST STEEL SWING CHECK VALVES ASME CLASS 600

SIZE 2 "to 20 "
Flanged and Butt weld Ends
Bolted Cover Type.
R.F. End Type. Fig. No. C4640
R.J. End Type. Fig. No. C4670
B.W. End Type. Fig. No. C4630

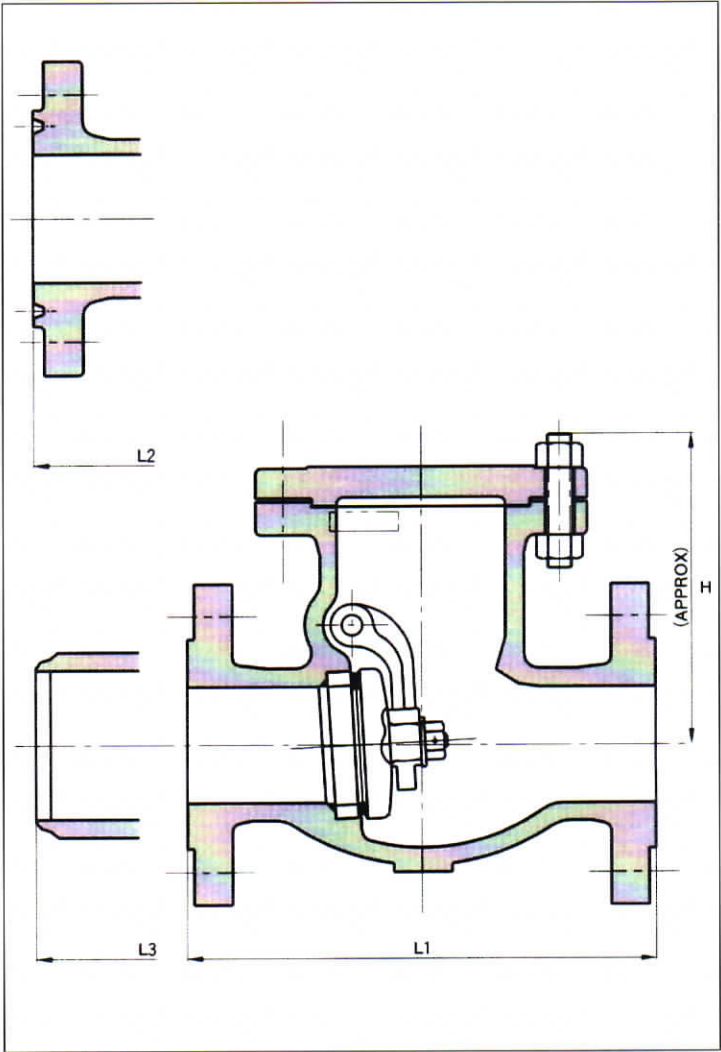

PRESSURE TEST: As per API 598

MATERIAL

NAME OF PART	ASTM	JIS
BODY	A216 WCB	SCPH2
BODY SEAT RING	* A105	* SFVC2A
DISC	4" & UNDER	* A105
	6" & OVER	* A216 WCB
HINGE	A216 WCB	SCPH2
HINGE PIN	A276 410/420	SUS403
COVER	A216 WCB	SCPH2
COVER BOLT	A193 B7	SNB7
COVER BOLT NUT	A194 2H	S45C
COVER GASKET	SPIRAL WOUND GRAPHOIL	
KNOCK PIN	A276 304	SUS304
DISC NUT	A276 410/420	SUS403
DISC WASHER	A276 410/420	SUS403
PLUG	A276 410/420	SUS403
NAME PLATE	B209M	ALP
PLUG GASKET	A576	MILD STEEL

* BODY SEAT RING: STELLITE FACE
 * DISC: 13Cr FACE

Note: (1) Valves 6 inch and over are equipped with eye-bolts.(Mild Steel)

WEIGHT AND DIMENSIONS

Valve Size			2"	2½"	3"	4"	6"	8"	10"	12"	14"	16"	18"	20"
End to End (mm)	R.F.	L1	292	330	356	432	559	660	787	838	889	991	1092	1194
	R.J.	L2	295	333	359	435	562	664	791	841	892	994	1095	1200
	B.W.	L3	292	330	356	432	559	660	787	838	889	991	1092	1194
Center to Top(mm)	H		181	202	219	282	332	391	427	481	513	655	679	703
Weight Approx.(kg)	R.F.		38	55	63	116	212	310	590	800	1110	1500	2000	2600
	R.J.		45	55	64	116	201	369	590	800	1110	1500	2000	2600
	B.W.		34	42	50	85	167	281	430	620	940	1250	1700	2200

Main Products

Gate valves / Globe valves / Check valves / Soft seat valves / Twin-Pack valves / Jacketed valves / Electric-motor operated valves / Air-motor operated valves / Air-cylinder operated valves / High pressure and high temperature service valves / Low temperature service valves



Ishida Valve Group

Ishida Valve Mfg. Co., Ltd.

Ishida Valve Engineering Co., Ltd.

Head Office : Fujishima Bldg.,13-4 Shiba 4-chome, Minato-ku,Tokyo 108-0014 Japan
TEL:03(3455)5271 FAX:03(3455)8690

WARRANTY.. Ishida Valve Mfg. Co., Ltd. warrants its products included parts to the original purchaser for a period of one year from and after the date of shipment against defects in material and workmanship under proper and normal use and service and not caused or resulting from improper application or usage, improper installation, improper maintenance and repairs, modifications or alternation.

Purchaser shall give notice to Ishida upon finding of any defect, or assuming defect, and Ishida has privilege to check the facts and defect

Ishida sole obligation under this warranty shall be limited to the following,

- (1) repair of the material or,
- (2) replacement of the materials or,
- (3) refund the purchase price on receipt of the defective product.

Ishida is not responsible to any kind of claims for consequential damage, loss or expense arising out of the defect.

Main Products

Gate valves / Globe valves / Check valves / Soft seat valves / Twin-Pack valves / Jacketed valves / Electric-motor operated valves / Air-motor operated valves / Air-cylinder operated valves / High pressure and high temperature service valves / Low temperature service valves



Ishida Valve Group

Ishida Valve Mfg. Co., Ltd.

Ishida Valve Engineering Co., Ltd.

Head Office : Fujishima Bldg.,13-4 Shiba 4-chome, Minato-ku,Tokyo 108-0014 Japan
TEL:03(3455)5271 FAX:03(3455)8690

WARRANTY.. Ishida Valve Mfg. Co., Ltd. warrants its products included parts to the original purchaser for a period of one year from and after the date of shipment against defects in material and workmanship under proper and normal use and service and not caused or resulting from improper application or usage, improper installation, improper maintenance and repairs, modifications or alternation.

Purchaser shall give notice to Ishida upon finding of any defect, or assuming defect, and Ishida has privilege to check the facts and defect

Ishida sole obligation under this warranty shall be limited to the following,

- (1) repair of the material or,
- (2) replacement of the materials or,
- (3) refund the purchase price on receipt of the defective product.

Ishida is not responsible to any kind of claims for consequential damage, loss or expense arising out of the defect.